

# ANT-2.4-CW-RCL

## Data Sheet

### Product Description

The RCL Series is useful in products where additional height above the product's case is needed or a slightly wider operational bandwidth is desired. The 2.45GHz version has a center-fed  $\frac{1}{2}$ -wave element with an internal ground reference.

### Features

- Right-angle mount
- Reduced-height whip
- Excellent performance
- Omni-directional pattern
- Fully weatherized
- Rugged & damage-resistant
- Part 15 compliant RP-SMA connector

### Electrical Specifications

Center Frequency:	2.45GHz
Recom. Freq. Range:	2.40–2.50GHz
Wavelength:	$\frac{1}{2}$ -wave
VSWR:	$\leq 1.9$ typical at center
Peak Gain:	1.1 dBi
Impedance:	50-ohms
Connector:	RP-SMA
Oper. Temp. Range:	$-20^{\circ}\text{C}$ to $+85^{\circ}\text{C}$

Electrical specifications and plots measured on 10.16 cm x 10.16 cm (4.00" x 4.00") reference ground plane

### Ordering Information

ANT-2.4-CW-RCL

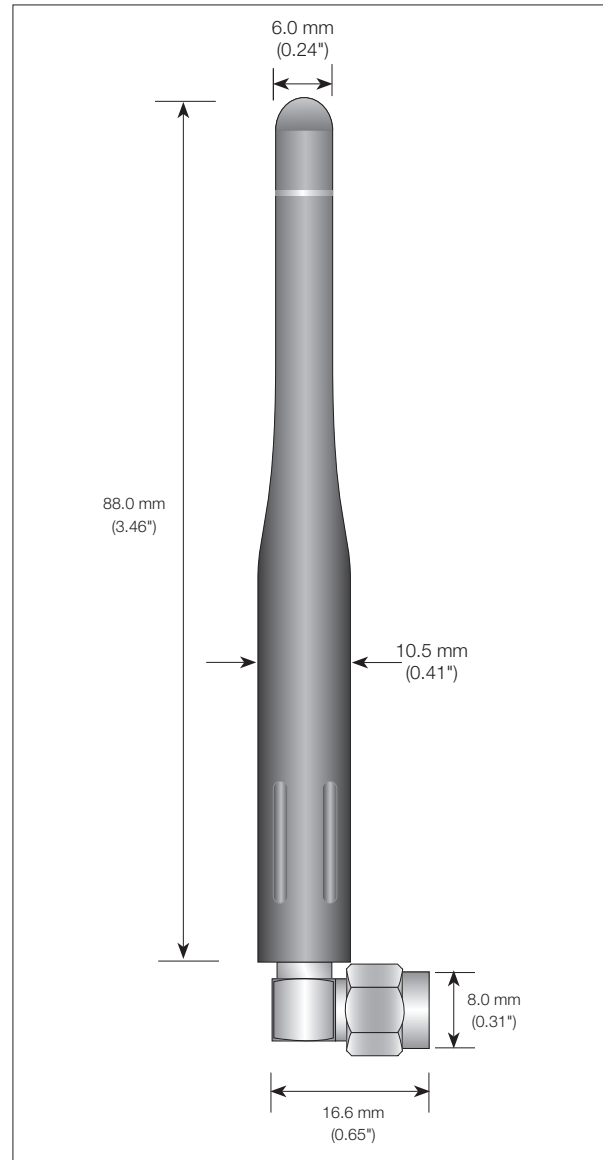

## VSWR Graph

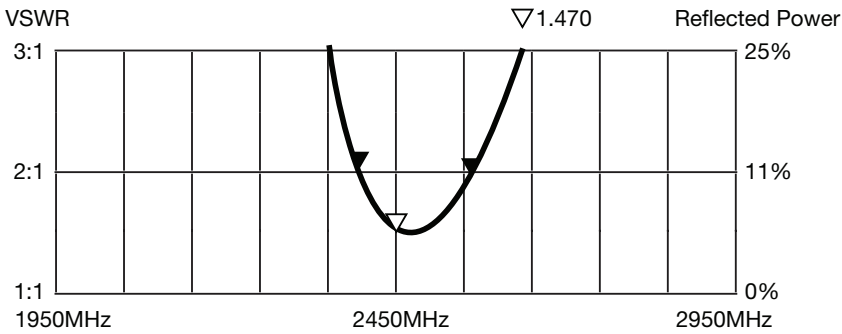

### What is VSWR?

The Voltage Standing Wave Ratio (VSWR) is a measurement of how well an antenna is matched to a source impedance, typically 50-ohms. It is calculated by measuring the voltage wave that is headed toward the load versus the voltage wave that is reflected back from the load. A perfect match will have a VSWR of 1:1. The higher the first number, the worse the match, and the more inefficient the system. Since a perfect match cannot ever be obtained, some benchmark for performance needs to be set. In the case of antenna VSWR, this is usually 2:1. At this point, 88.9% of the energy sent to the antenna by the transmitter is radiated into free space and 11.1% is either reflected back into the source or lost as heat on the structure of the antenna. In the other direction, 88.9% of the energy recovered by the antenna is transferred into the receiver. As a side note, since the “:1” is always implied, many data sheets will remove it and just display the first number.

### How to Read a VSWR Graph

VSWR is usually displayed graphically versus frequency. The lowest point on the graph is the antenna’s operational center frequency. In most cases, this will be different than the designed center frequency due to fabrication tolerances. The VSWR at that point denotes how close to 50-ohms the antenna gets. Linx specifies the recommended bandwidth as the range where the typical antenna VSWR is less than 2:1.

# Mouser Electronics

Authorized Distributor

Click to View Pricing, Inventory, Delivery & Lifecycle Information:

[Linx Technologies:](#)

[ANT-2.4-CW-RCL](#)